

AUTOMATIC GIRTH WELDERS

Single and Double Sided Models



Energia Red-D-Arc / Ransome's AGW Automatic Girth Welder is an automatic system that speeds up construction of field-erected storage tanks. It straddles the shell plates riding on adjustable flanged wheels at operator controlled speeds of 4 to 105 IPM (.10—2.67 M/min). It can handle plates as thick as 2 inches and tank diameters from 15 feet and up. Available as dual or single sided machines. Each is equipped with welding heads, controls, flux support belts and recovery units so that 3 and 9 o'clock welds can be made simultaneously. The Lincoln NA-3 solid state control and welding head fitted with nozzles, wire feed rolls, straighteners and 50 Lbs. (22.7Kg) wire reels for either single or Twin-arc wire are standard. Submerged arc flux belt mechanism ensures retention of the flux at the joint, and efficient recycling of flux. Open arc models are available upon request.

Adjustable Frame for Plates 6' to 10' Tall

Features

- ◆ Effectively cuts welding time up to 40%
- ◆ Adjustable frame for plates 6ft to 10ft tall (1.8m-3m)
- ◆ Unlimited tank diameters down to 15' in diameter
- ◆ High / low rapid travel select controls
- ◆ Self propelled at speeds from 4 to 105 IPM
- ◆ Plates up to 2" thick
- ◆ Single and Double sided operation



Specifications

AUTOMATIC GIRTH WELDERS



Includes

- Operator's Platform with seat
- Lincoln **NA-3** Wire Feeder and Control
- Lincoln **DC-600** or **DC-1000** Power Source
- Vertical Adjuster
- Horizontal Adjuster
- Flux Belt Assembly
- Flux Recirculating System
- Lincoln Tiny Twin Wire Kit
- Pre-Heat Torch
- Service Skid with Disconnect
- Tropicalized Controls.
- Weather Curtains
- 200 feet** of Control Cable Assembly
- Loading Safety Wheels
- Operator Communication System (*AGW-II Only*)
- Operators Manual
- Tool Kit

Notes

- ◆ NA-5 Controls Available
- ◆ CE-Mark Compliant Models Available
- ◆ Custom Engineered Models Available

Adjustable tubular frame for plates 6ft to 10ft tall (1.8m-3.05m)
Min. 20ft(6.1m) to an Unlimited tank diameter range
Travel speeds 4-105 ipm (.10-2.67 m/min)
Speed, direction and rapid travel select controls (Master side)

*Average welding speed is approximately 30 ipm (.762 m/min)
with a deposition rate of 11# per hour. (per side)*

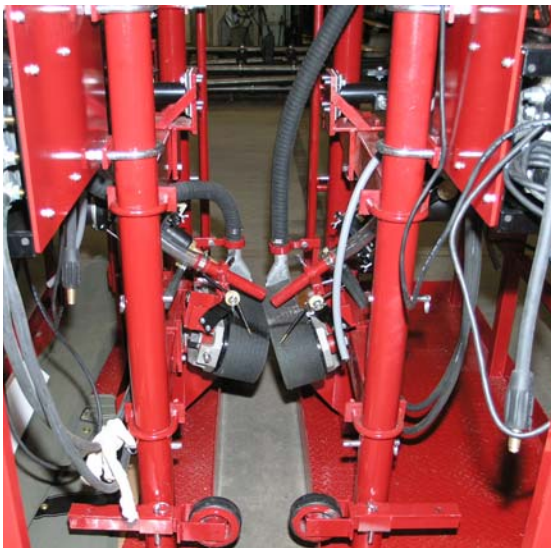

Ajith Vylon Rodrigues
Welding Division Head
ENERGIA MTC LLC
Tel: +966 13 3417757 Fax: +966 13 3420141
Mobile: +966 509630706
Email: ajithrodrigues@energiaksa.com
www.energiaksa.com

Red-D-Arc
Welderentals

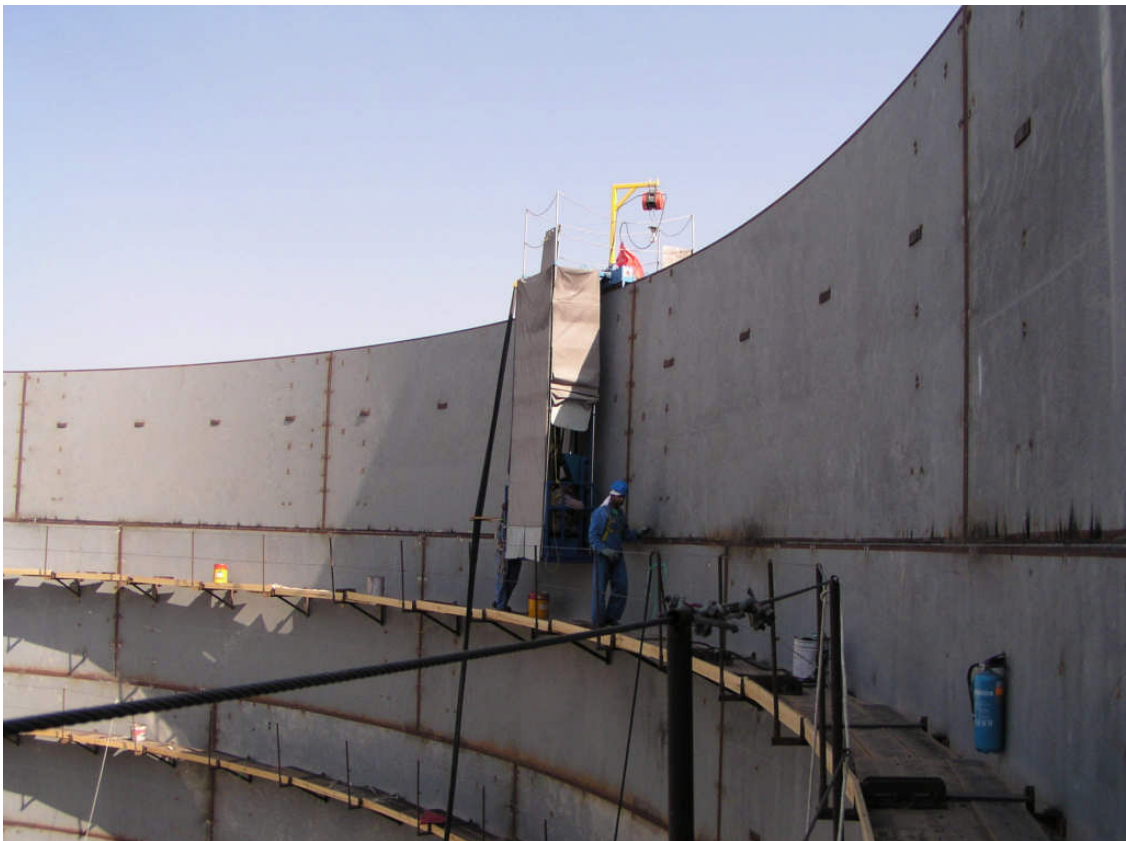

SUBMERGED ARC INTRODUCTION

The submerged arc welding (SAW) process was developed in the early 1940s. This process is different from other electric arc welding methods. The arc is submerged under the powdered fusible granulated material, commonly called flux, is used to shield the arc and protect the molten metal. Since the arc is completely covered by the granulated flux the weld is produced without the visible arc. The nature of the arc and flux coverage is such that very little smoke or visible fumes are developed. The flux is fed by either a gravity system or by a pressurized method into the arc zone through a concentric nozzle or applied in advance of the arc through a hose or fitting.

During the welding operation, the heat of the arc melts some of the flux along with the tip of the continuously fed electrode and a portion of the base metal. As the electrode progresses along the joint, the lighter liquefied flux rises above the molten metal and solidifies in the form of slag. The weld metal solidifies while the slag above it remains molten, later solidifying over the newly deposited weld metal, thereby protecting the arc and molten metal from contamination by the atmospheric oxygen and nitrogen. The unfused particles of granulated flux are normally picked up manually or with a vacuum system and re-fed into the flux holding system. The solidified slag is removed and normally discarded. A schematic representation of the SAW process is shown in the diagram. Amongst the available arc welding processes for joining steel, submerged arc welding is probably the most commonly used mechanized process.

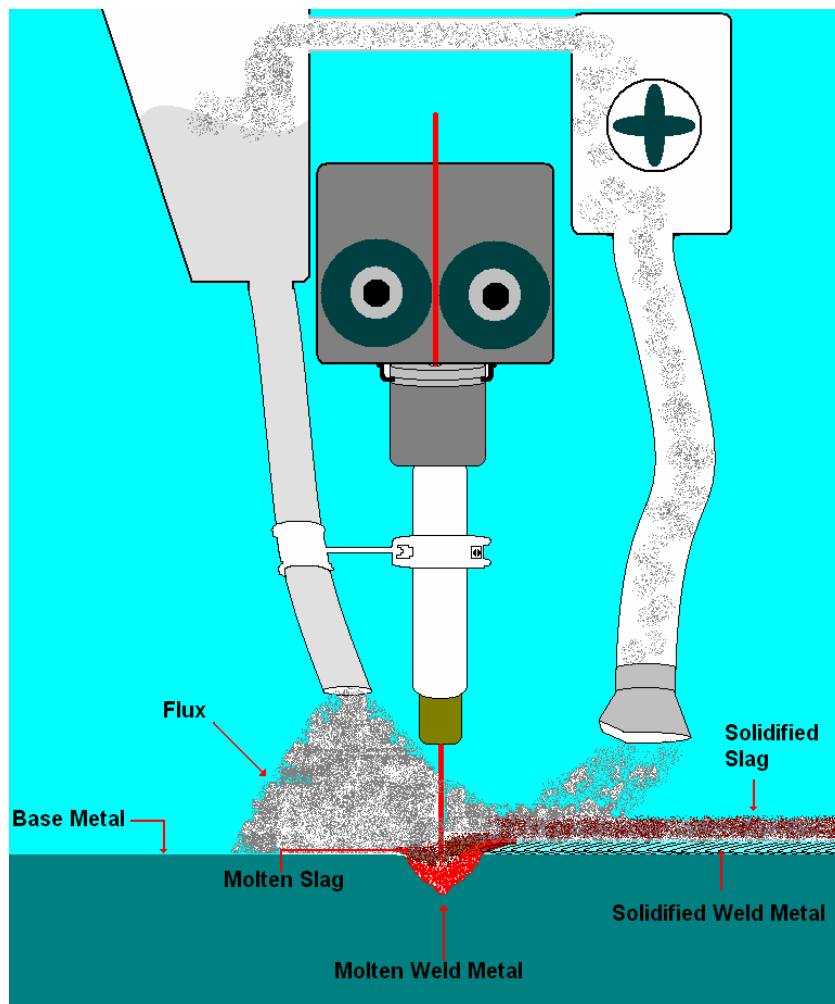

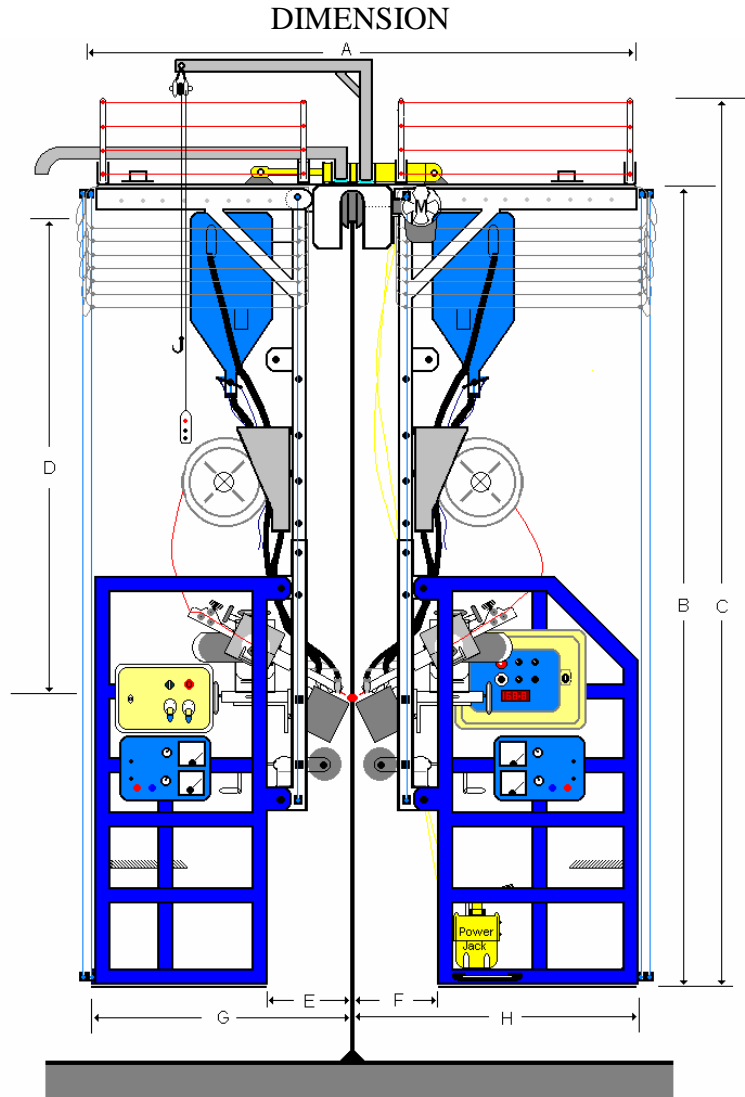

SPECIFICATIONS

- A: 6.9'
- B: 13.8'
- C: 17.5'
- D: 5.9' to 10.5' adjustable
- E: 13.6"
- F: 13.6"
- G: 3'
- H: 4.2'

- Height increment: 11.8" (300mm).
- Travel speed: 3.9" ipm to 113.4" ipm
- Input Power: 110VAC/50hz/1ph. (alternative 400vac 50Hz/3ph)
- Carrying Pay load: 300Kg each side.
- Flux hoist capacity: 70kg
- Shell height: 5.9' (1.8M) to 9.8' (3M).
- Shell thickness: 0.375"(9.5mm) min to 1.96" (50mm) max.

SHELL PLATE REQUIREMENT HEIGHT

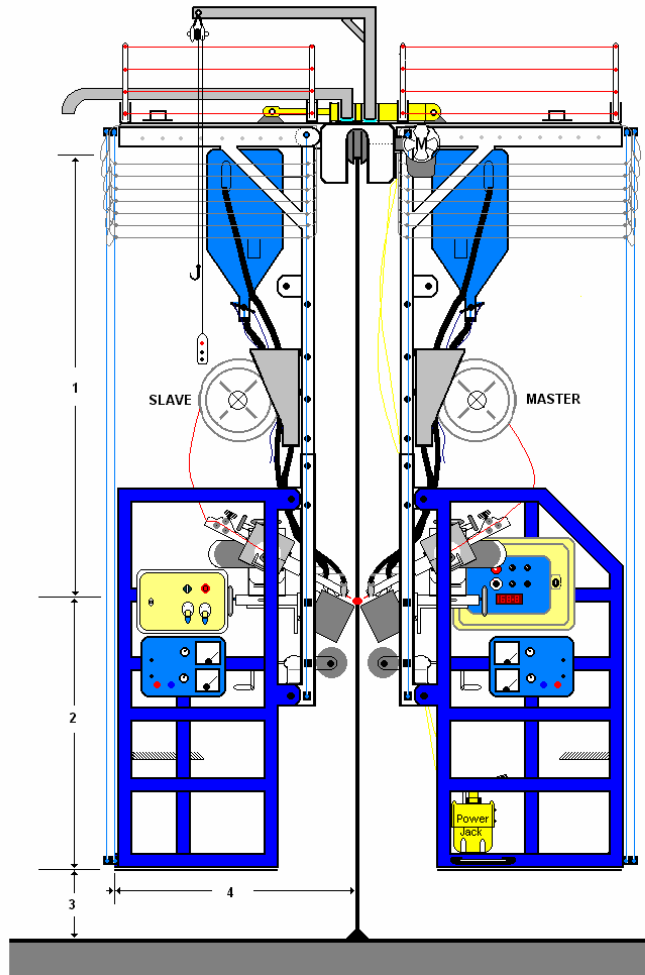
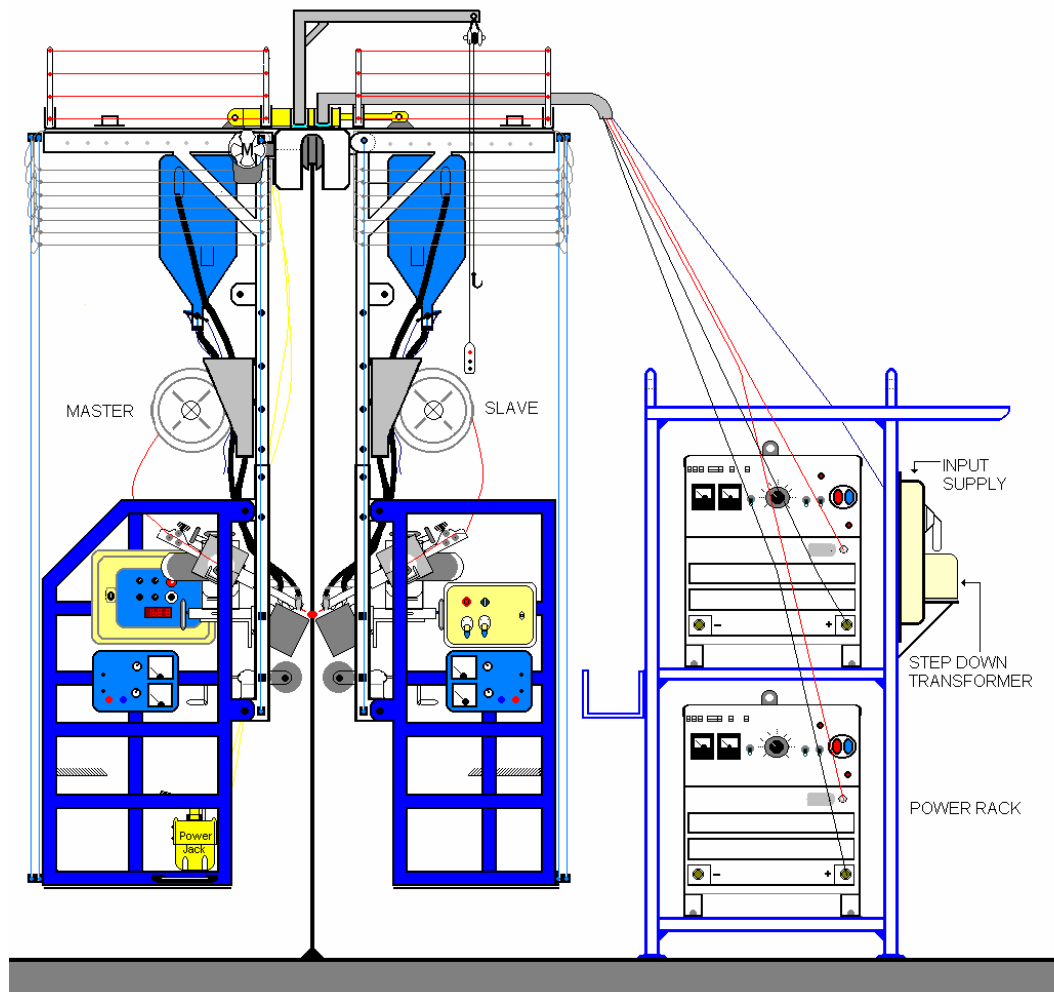

PLATE HEIGHT	1	2	3	4
6'	6'(1828.8mm)	5.3'(1628.8mm)	7.9"(200mm)	3'(921mm)
8'	8'(2438.4mm)	5.3'(1628.8mm)	3.96'(809.6mm)	3'(921mm)
10	10'(3048mm)	5.3'(1628.8mm)	4.65'(1419.2mm)	3'(921mm)

Note: For 12' and above shell plate can be done. Consult factory the detail shell plate requirement.

AUTOMATIC GIRTH WELDER LAYOUT



System consist of:

- A-Frame carriage assembly**
- Platform & handrail**
- All weather curtains**
- Collapsible LNG rack**
- Main Controller console**
- Wire feed control system**
- Weld head motor assembly**
- Wire reel assembly**
- Flux hopper assembly**
- Flux belt and roller assembly**
- Flux recovery system**
- 6' X-Y slide adjuster**
- Flux recovery system**
- Electric hoist**
- Auxiliary power**

Power Pack assembly

Romar AGW-2 is a double sided, self-propelled automatic girth welder complete with fully integrated submerged arc welding system. It is a system that is designed for construction of field-erected storage tank that can speed up the horizontal welding process up to 40 over percent versus the manual stick application. It rides on the edge of the tank diameter from 15' (4.6m) to unlimited diameter. Travel speed is controlled by operator from minimum 3.9 inches per minute to 113.4 inches per minute maximum. With the telescopic column design it can handle shell plate height from 5.9'(1.8m) to 13'(4m) and thickness from 0.375"(9.5mm) min to 1.96" (50mm) max.

The system consist of



Carriage

Powered by 1 hp DC motor through gear reducer. Solid-state electronic unit control the carriage travel speed range from 3.9 inches per minute to 113.4 inches per minute.

Platform

Includes handrail, weather curtains, operator-seat and ladder for operator to access.

Cylinder rack

A collapsible LPG rack located on the side of the carriage. Heating torches and cylinder bottle will NOT supply with the machine.



Auxiliary box

Includes 1 out-put power of 110 VAC or 220 VAC 1ph/13amps

Wire feeder controller

Wire feeder Controller ability to perform on CC/CV applications. Function includes wire feed speed, start & carter fill, volt & amperes meter. Interface with main control box to provide an auto start with carriage travel and flux recovery function.

Controller Console

Includes on/off selector switch, Travel manual/auto mode, forward/reverse selector switch, travel speed potentiometer, flux recovery manual/auto mode, flux on/off switch, main fuse and digital display meter.



Flux belt

4" width flux belt self-driven mechanism holds the flux and convey the flux to the flux recovery pick-up nozzle during operation.

Cross slide adjuster

A set of X-Y slide adjuster 4" stroke supported the weld head movement. Make easy for operator to fine-tune the position of the nozzle before or during welding.

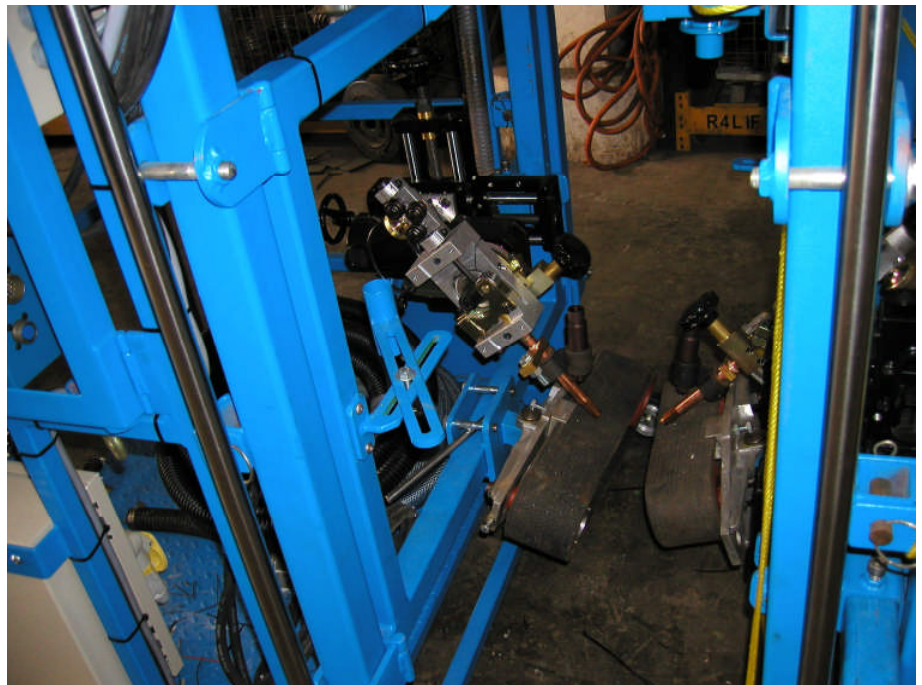

Wire drive assembly

115V heavy-duty motor drive assembly with gear reducer built in. Speed ranges 0-400 inches per minute comes with a one size drive roll, wire straightener and 180° nozzle.

Flux recovery system

A 3 watts /110VAC Electric driven flux recovery unit designed to resist the abrasive nature of the flux comes with a primary separator tank and butterfly valve. Manual release the flux and channel it to a 25lbs capacity flux hopper. A 2 x 2OD heavy-duty rubber hose with pick-up tools is also provided.

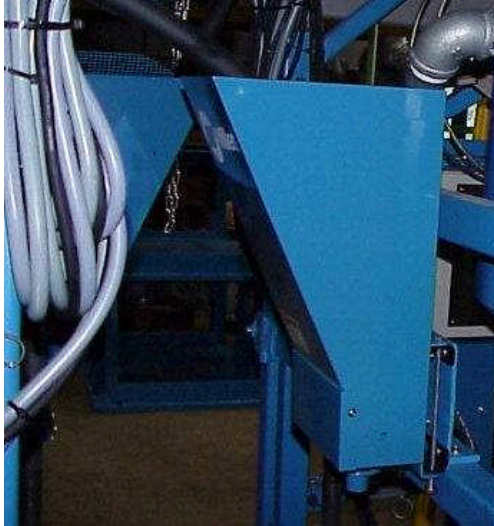

25lbs flux hopper



Separator tank



Power Pack

Hydraulic power pack operates the cylinder straddling across the top platform for the purpose of opening and closing the A-frame.

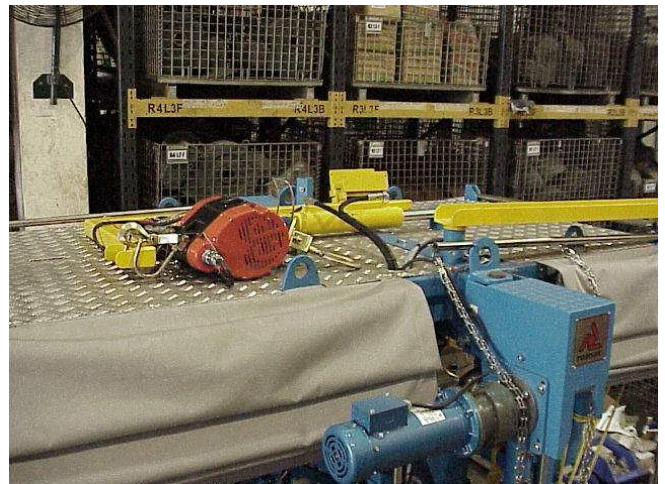

Electric hoist

The electric hoist is operated at 110VAC manual push button. Lifting capacity of 70kg.

Optional item

Pre-heating torches
Operators phone set.

CONSOLE LAYOUT

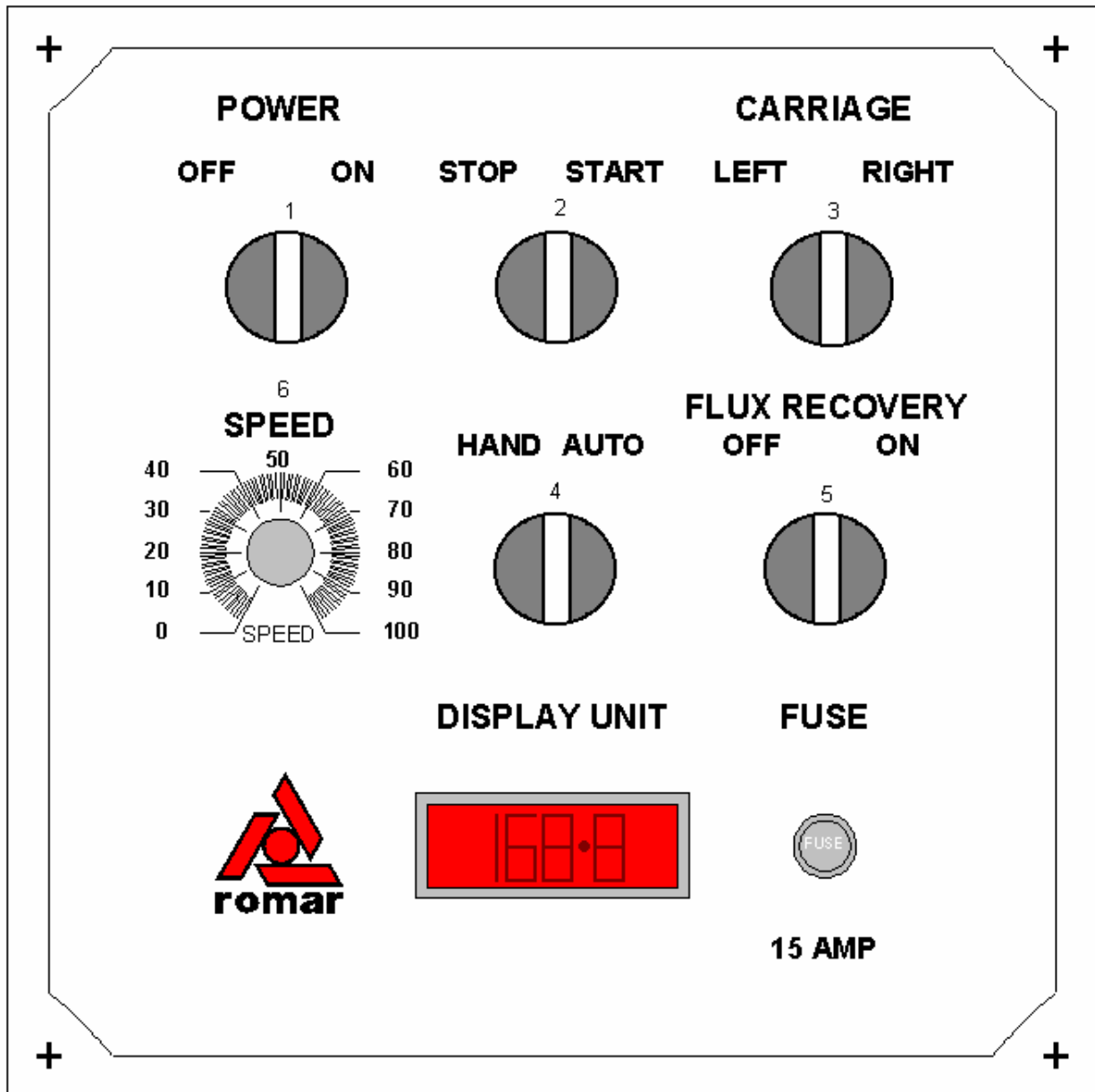

This console provides the electrical component for the function of the AGW except the welding process, which is controlled via the Wire feeder. The main Panel allows the distribution of incoming supply to the transformer so that AGW operate at 110V.

Function

Power: ON / OFF selector switch

Travel: Start / Stop Selector

Travel: Left / Right Selector

Travel: Speed adjustment

Flux: Recovery Mode Hand / Auto Selector

Flux: Recovery ON / OFF Selector

Fuse: Main fuse

Digital: Displaying figure that related to the speed desired by operator.

SET-UP GUIDELINES

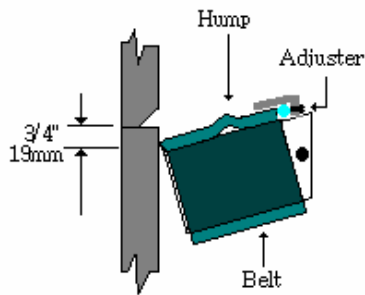

Flux belt should be positioned approx $\frac{3}{4}$ " below of the bottom plate. As shown on the left.

Made a slight hump to exert pressure against the belt to assure maximum contact with the shell plate to prevent spillage of the flux.

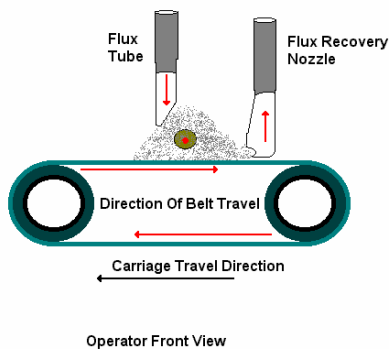

This belt is a continuous belt running over two rollers. It is essential that this belt be held tightly against the side of the tank to stop spillage of the flux. If spillage does occur, the weld profile will be destroyed.

Flux recovery nozzle should be tilted slightly backward to allow a proper pick up the unused flux efficiently.

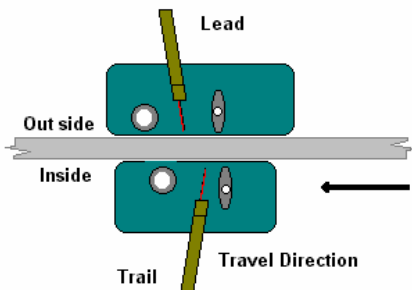

The two wires must never be place opposite each other. Ideally 2" to 3" away.

The flux tube (feeding) should set about 1" away from the tip
 40" flux belt on the outer side
 32" flux belt on the inter side

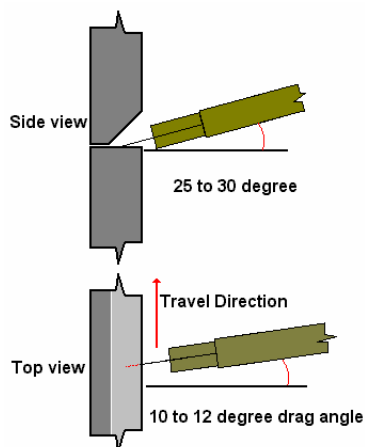

Nozzle Angle.

Nozzle pointed downward at 25 to 30 degree for plate thickness .5" to .68 plates.

10 to 15 degree drag angle to keep the molten slag from running ahead of the weld pool at all times.

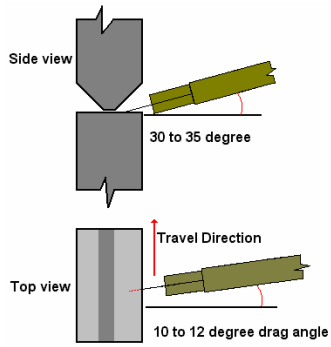

Nozzle Angle.

Nozzle pointed downward at 30 to 35 degree for plate thickness $\frac{3}{4}$ to 1" plates.

15 to 20 degree drag angle to keep the molten slag from running ahead of the weld pool at all times.

AGW Mounting Skid

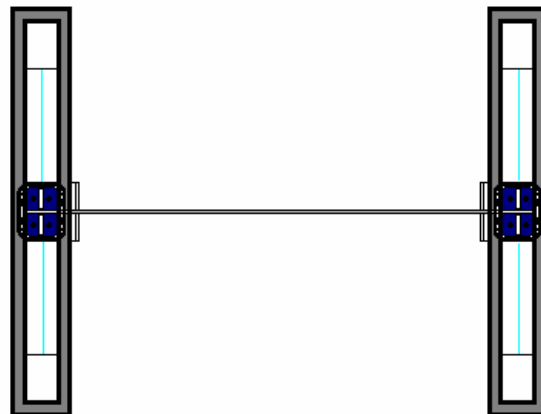
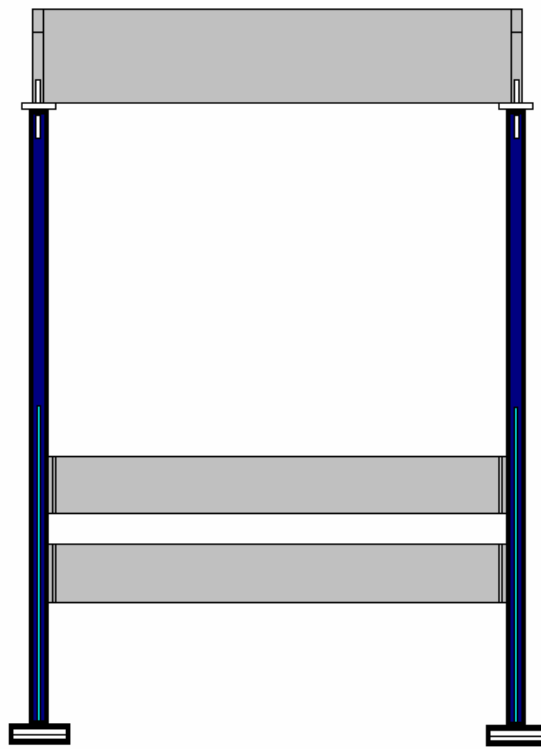
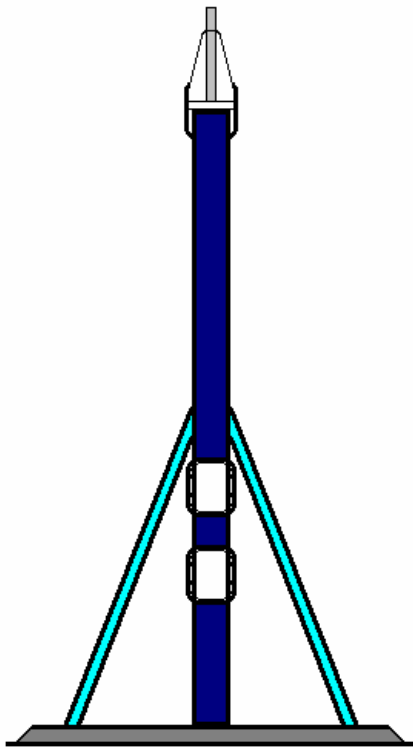

Notes:
This Skid are intended for mounting AGW and making a procedure test on AGW system. Client needs to prepare the skid prior to the arrival of the machine.

Consult factory for detail drawing.

Welding Guidelines

	Outside		Inside
Plate Thickness: 6 & 8 mm Electrode Size: 1/8"	Volt: 25 to 27 Amps: 400 to 440 T/S: 26 /26IPM Passes: 1		Volt: 25 to 27 Amps: 400 to 440 T/S: 26 /26IPM Passes: 1
Plate Thickness: 8 & 10 mm Electrode Size: 1/8"	Volt: 26 to 27 Amps: 420 to 480 T/S: 26/26IPM Passes: 2		Volt: 26 to 27 Amps: 420 to 480 T/S: 26IPM Passes: 1
Plate Thickness: 10 & 13 mm Electrode Size: 1/8"	Volt: 25 to 27 Amps: 450 to 470 T/S: 26/26IPM Passes: 2		Volt: 25 to 27 Amps: 450 to 470 T/S: 26/26IPM Passes: 2
Plate Thickness: 13 & 16 mm Electrode Size: 1/8"	Volt: 25 to 27 Amps: 480 to 520 T/S: 26/35 IPM Passes: 2		Volt: 25 to 27 Amps: 450 to 520 T/S: 26/35 IPM Passes: 2
Plate Thickness: 16 & 18 mm Electrode Size: 1/8"	Volt: 26 to 27 Amps: 530 to 570 T/S: 27/30 IPM Passes: 2		Volt: 26 to 27 Amps: 480 to 600 T/S: 27/30 IPM Passes: 2
Plate Thickness: 18 & 22 mm Electrode Size: 1/8"	Volt: 26 to 29 Amps: 480 to 570 T/S: 26/35/35 IPM Passes: 3		Volt: 26 to 29 Amps: 480 to 660 T/S: 26/35/35 IPM Passes: 3
Plate Thickness: 22 & 25 mm Electrode Size: 1/8"	Volt: 26 to 29 Amps: 480 to 520 T/S: 22/22/28 IPM Passes: 3		Volt: 26 to 29 Amps: 480 to 550 T/S: 22/22/28 IPM Passes: 3

This parameter is supplied as a guide for establishing a welding procedure.
 For more detail information consult consumables manufactures.

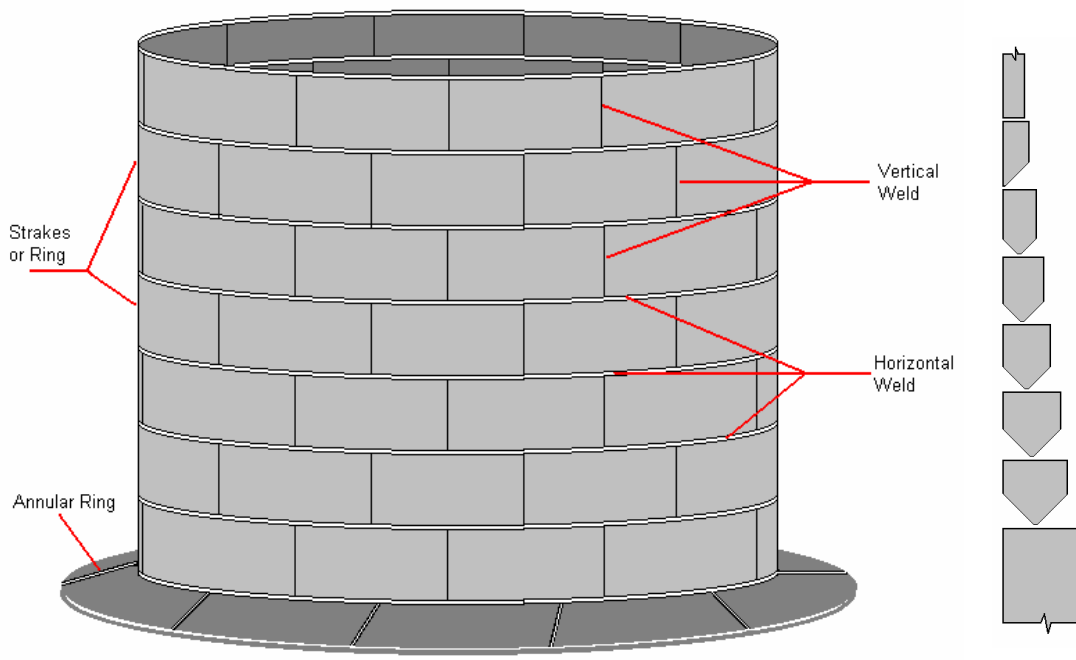

Note:

For thick sections a manual root pass is firstly put in to stop the chances of root bead cracking. Minimum root gap is 2mm for thin material and 4mm for 1" thick material.